

Chapter 2

2.1 d. $\gamma = \frac{(87.5)(9.81)}{(1000)(0.05)} = \mathbf{17.17 \text{ kN/m}^3}$

c. $\gamma_d = \frac{\gamma}{1+w} = \frac{17.17}{1+0.15} = \mathbf{14.93 \text{ kN/m}^3}$

a. Eq. (2.12): $\gamma = \frac{G_s \gamma_w}{1+e}$. $14.93 = \frac{(2.68)(9.81)}{1+e}$; $e = \mathbf{0.76}$

b. Eq. (2.6): $n = \frac{e}{1+e} = \frac{0.76}{1+0.76} = \mathbf{0.43}$

e. Eq. (2.14): $S = \frac{V_w}{V_v} = \frac{wG_s}{e} = \left[\frac{(0.15)(2.68)}{0.76} \right] (100) = \mathbf{53\%}$

2.2 a. From Eqs. (2.11) and (2.12), it can be seen that,

$$\gamma_d = \frac{\gamma}{1+w} = \frac{20.1}{1+0.22} = \mathbf{16.48 \text{ kN/m}^3}$$

b. $\gamma = 16.48 \text{ kN/m}^3 = \frac{G_s \gamma_w}{1+e} = \frac{G_s (9.81)}{1+e}$

Eq. (2.14): $e = wG_s = (0.22)(G_s)$. So,

$$16.48 = \frac{9.81G_s}{1+0.22G_s}; \quad G_s = \mathbf{2.67}$$

Chapter 2

2.3 a. $\gamma = \frac{G_s \gamma_w (1+w)}{1+e}$. $119.5 = \frac{(2.65)(62.4)(1+0.12)}{1+e}$; $e = \mathbf{0.55}$

b. $n = \frac{0.55}{1+0.55} = \mathbf{0.355}$

c. $S = \frac{w G_s}{e} = \frac{(0.12)(2.65)}{0.55} \times 100 = \mathbf{57.8\%}$

d. $\gamma_d = \frac{\gamma}{1+w} = \frac{119.5}{1+0.12} = \mathbf{106.7 \text{ lb/ft}^3}$

2.4 a. $G_s = \frac{e}{w}$. $\gamma_d = \frac{\left(\frac{e}{w}\right)(\gamma_w)}{1+e}$. $85.43 = \frac{\left(\frac{e}{0.36}\right)(62.4)}{1+e}$; $e = \mathbf{0.97}$

b. $n = \frac{e}{1+e} = \frac{0.97}{1+0.97} = \mathbf{0.49}$

c. $G_s = \frac{e}{w} = \frac{0.97}{0.36} = \mathbf{2.69}$

d. $\gamma_{\text{sat}} = \frac{(G_s + e)\gamma_w}{1+e} = \frac{(2.69 + 0.97)(62.4)}{1+0.97} = \mathbf{115.9 \text{ lb/ft}^3}$

2.5 From Eqs. (2.11) and (2.12): $\gamma_d = \frac{116.64}{1+0.08} = 108 \text{ lb/ft}^3$

Eq. (2.12): $\gamma_d = \frac{G_s \gamma_w}{1+e}$; $108 = \frac{(2.65)(62.4)}{1+e}$; $e = 0.53$

Eq. (2.23): $D_r = 0.82 = \frac{e_{\max} - e}{e_{\max} - e_{\min}} = \frac{e_{\max} - 0.53}{e_{\max} - 0.44}$; $e_{\max} = \mathbf{0.94}$

$\gamma_{d(\min)} = \frac{G_s \gamma_w}{1+e_{\max}} = \frac{(2.65)(62.4)}{1+0.94} = \mathbf{85.2 \text{ lb/ft}^3}$

2.6 Refer to Table 2.7 for classification.

Soil A: **A-7-6(9)** (Note: PI is greater than LL – 30.)

$$\begin{aligned} \text{GI} &= (\text{F}_{200} - 35)[0.2 + 0.005(\text{LL} - 40)] + 0.01(\text{F}_{200} - 15)(\text{PI} - 10) \\ &= (65 - 35)[0.2 + 0.005(42 - 40)] + 0.01(65 - 15)(16 - 10) \\ &= 9.3 \approx \mathbf{9} \end{aligned}$$

Soil B: **A-6(5)**

$$\begin{aligned} \text{GI} &= (55 - 35)[0.2 + 0.005(38 - 40)] + 0.01(55 - 15)(13 - 10) \\ &= 5.4 \approx \mathbf{5} \end{aligned}$$

Soil C: **A-3-(0)**

Soil D: **A-4(5)**

$$\begin{aligned} \text{GI} &= (64 - 35)[0.2 + 0.005(35 - 40)] + 0.01(64 - 15)(9 - 10) \\ &= 4.585 \approx \mathbf{5} \end{aligned}$$

Soil E: **A-2-6(1)**

$$\text{GI} = 0.01(\text{F}_{200} - 15)(\text{PI} - 10) = 0.01(33 - 15)(13 - 10) = 0.54 \approx \mathbf{1}$$

Soil F: **A-7-6(19)** (PI is greater than LL – 30.)

$$\begin{aligned} \text{GI} &= (76 - 35)[0.2 + 0.005(52 - 40)] + 0.01(76 - 15)(24 - 10) \\ &= 19.2 \approx \mathbf{19} \end{aligned}$$

- 2.7 Soil A: Table 2.8: 65% passing No. 200 sieve.
Fine grained soil; $LL = 42$; $PI = 16$
Figure 2.5: **ML**
Figure 2.7: Plus No. 200 $> 30\%$; Plus No. 4 = 0
 $\% \text{ sand} > \% \text{ gravel}$ – **sandy silt**
- Soil B: Table 2.8: 55% passing No. 200 sieve.
Fine grained soil; $LL = 38$; $PI = 13$
Figure 2.5: Plots below A-line – **ML**
Figure 2.7: Plus No. 200 $> 30\%$
 $\% \text{ sand} > \% \text{ gravel}$ – **sandy silt**
- Soil C: Table 2.8: 8% passing No. 200 sieve.
 $\% \text{ sand} > \% \text{ gravel}$ – sandy soil – SP
Figure 2.6: $\% \text{ gravel} = 100 - 95 = 5\% < 15\%$ – **poorly graded sand**
- Soil D: Table 2.8: 64% passing No. 200 sieve
Fine grained soil; $LL = 35$, $PI = 9$
Figure 2.5 – **ML**
Figure 2.7: $\% \text{ sand} (31\%) > \% \text{ gravel} (5\%)$ – **sandy silt**
- Soil E: Table 2.8: 33% passing No. 200 sieve; 100% passing No. 4 sieve.
Sandy soil; $LL = 38$; $PI = 13$
Figure 2.5: Plots below A-line – **SM**
Figure 2.6: $\% \text{ gravel} (0\%) < 15\%$ – **silty sand**
- Soil F: Table 2.8: 76% passing No. 200 sieve; $LL = 52$; $PI = 24$
Figure 2.5: **CH**
Figure 2.7: Plus No. 200 is $100 - 76 = 24\%$
 $\% \text{ gravel} > \% \text{ gravel}$ – **fat clay with sand**

$$2.8 \quad \gamma_d = \frac{G_s \gamma_w}{1+e}; \quad e = \frac{G_s \gamma_w}{\gamma_d} - 1 = \frac{(2.68)(62.4)}{117} - 1 = 0.43$$

$$\text{Eq. (2.37): } \frac{k_1}{k_2} = \frac{\left(\frac{e_1^3}{1+e_1}\right)}{\left(\frac{e_2^3}{1+e_2}\right)}; \quad \frac{0.22}{k_2} = \frac{\left(\frac{0.63^3}{1+0.63}\right)}{\left(\frac{0.43^3}{1+0.43}\right)}; \quad k_2 = \mathbf{0.08 \text{ cm/s}}$$

2.9 From Eq. (2.41):

$$\frac{k_1}{k_2} = \left(\frac{1+e_2}{1+e_1}\right) \left(\frac{e_1}{e_2}\right)^n; \quad \text{or } \frac{0.2 \times 10^{-6}}{0.91 \times 10^{-6}} = \left(\frac{2.9}{2.2}\right) \left(\frac{1.2}{1.9}\right)^n; \quad 0.1667 = (0.6316)^n$$

$$n = \frac{\log(0.1667)}{\log(0.6316)} = \frac{-0.778}{-0.1996} = 3.898$$

$$C = \frac{k_1(1+e_1)}{e_1^n} = \frac{(0.2 \times 10^{-6})(2.2)}{1.2^{3.998}} = 0.216 \times 10^{-6}$$

$$k_3 = C \left(\frac{e^n}{1+e}\right) = \left(\frac{0.9^{3.998}}{1.9}\right) (0.216 \times 10^{-6}) = \mathbf{0.075 \times 10^{-6} \text{ cm/s}}$$

2.10 The flow net is shown.

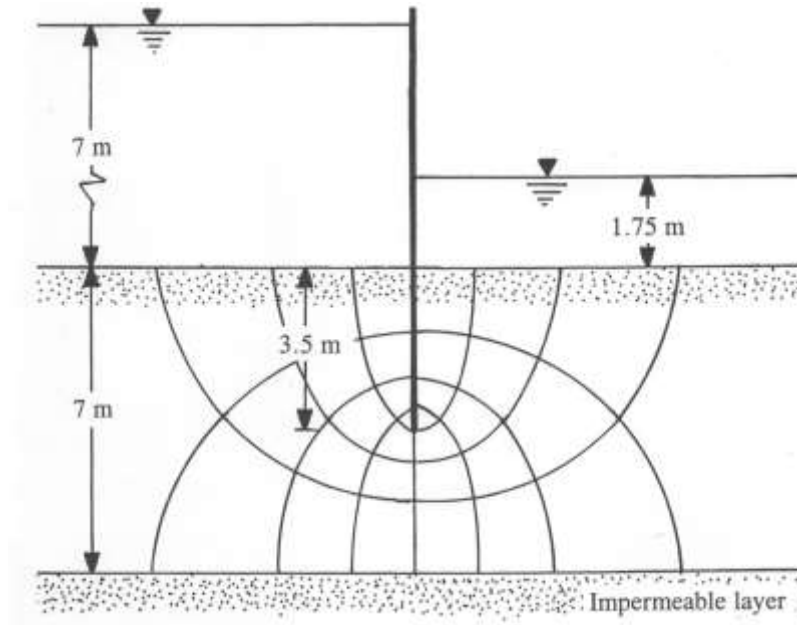

$$k = 6.5 \times 10^{-4} \text{ cm/s}; h_{\max} = H_1 - H_2 = 7 - 1.75 = 5.25 \text{ m. So,}$$

$$q = \left(\frac{6.5 \times 10^{-4}}{10^2} \right) \left[\frac{(5.25)(4)}{8} \right] = 17.06 \times 10^{-6} \text{ m}^3/\text{m/s}$$

2.11 a. $k = 2.4622 \left[D_{10}^2 \frac{e^3}{(1+e)} \right]^{0.7825} = 2.4622 \left[(0.2)^2 \left(\frac{0.6^3}{1+0.6} \right) \right]^{0.7825} = 0.041 \text{ cm/s}$

b. $k = 35 \left(\frac{e^3}{1+e} \right) C_u^{0.6} (D_{10})^{2.32} = (35) \left(\frac{0.6^3}{1+0.6} \right) \left(\frac{0.4}{0.2} \right)^{0.6} (0.2)^{2.32} = 0.171 \text{ cm/s}$

$$2.12 \quad \gamma_{\text{dry(sand)}} = \frac{G_s \gamma_w}{1+e} = \frac{(2.66)(9.81)}{1+0.55} = 16.84 \text{ kN/m}^3$$

$$\gamma_{\text{sat(sand)}} = \frac{G_s \gamma_w + e \gamma_w}{1+e} = \frac{(9.81)(2.66+0.48)}{1+0.48} = 20.81 \text{ kN/m}^3$$

$$\gamma_{\text{sat(clay)}} = \frac{G_s \gamma_w (1+w)}{1+w G_s} = \frac{(2.74)(9.81)(1+0.3478)}{1+(0.3478)(2.74)} = 18.55 \text{ kN/m}^3$$

At A: $\sigma = 0$; $u = 0$; $\sigma' = 0$

At B: $\sigma = (16.84)(3) = 50.52 \text{ kN/m}^2$

$u = 0$

$\sigma' = 50.52 \text{ kN/m}^2$

At C: $\sigma = \sigma_B + (20.81)(1.5) = 50.52 + 31.22 = 81.74 \text{ kN/m}^2$

$u = (9.81)(1.5) = 14.72 \text{ kN/m}^2$

$\sigma' = 81.74 - 14.72 = 67.02 \text{ kN/m}^2$

At D: $\sigma = \sigma_C + (18.55)(5) = 81.74 + 92.75 = 174.49 \text{ kN/m}^2$

$u = (9.81)(6.5) = 63.77 \text{ kN/m}^2$

$\sigma' = 174.49 - 63.77 = 110.72 \text{ kN/m}^2$

2.13 Eq. (2.54): $C_c = 0.009(LL - 10) = 0.009(42 - 10) = 0.288$

Eq. (2.65):

$$S_c = \frac{C_c H_c}{1+e_o} \log \frac{\sigma'_o + \Delta\sigma'}{\sigma'_o} = \frac{(0.288)(3.7 \times 1000 \text{ mm})}{1+0.82} \log \left(\frac{155}{110} \right) = 87.2 \text{ mm}$$

2.14 Eq. (2.69):

$$S_c = \frac{C_s H_c}{1+e_o} \log \left(\frac{\sigma'_c}{\sigma'_o} \right) + \frac{C_c H_c}{1+e_o} \log \frac{\sigma'_o + \Delta\sigma'}{\sigma'_c}$$

$$= \frac{\left(\frac{0.288}{5} \right) (3700 \text{ mm})}{1+0.75} \log \left(\frac{128}{110} \right) + \frac{(0.288)(3700)}{1+0.82} \log \left(\frac{155}{128} \right) = 56.69 \text{ mm}$$

$$2.15 \quad \text{a. Eq. (2.53): } C_c = \frac{e_1 - e_2}{\log\left(\frac{\sigma'_2}{\sigma'_1}\right)} = \frac{0.91 - 0.792}{\log\left(\frac{300}{150}\right)} = 0.392$$

$$\text{From Eq. (2.65): } S_c = \frac{C_c H_c}{1 + e_o} \log \frac{\sigma'_o + \Delta\sigma'}{\sigma'_o}$$

Using the results of Problem 2.12,

$$\sigma'_o = (3)(16.84) + 1.5(20.81 - 9.81) + \frac{5}{2}(18.55 - 9.81) = 88.87 \text{ kN/m}^2$$

$$e_o = wG_s = (0.3478)(2.74) = 0.953$$

$$S_c = \frac{(0.392)(5000 \text{ mm})}{1 + 0.953} \log\left(\frac{88.87 + 50}{88.87}\right) = \mathbf{194.54 \text{ mm}}$$

$$\text{b. Eq. (2.73): } T_v = \frac{C_v t}{H^2}. \text{ For } U = 50\%, T_v = 0.197 \text{ (Table 2.11). So,}$$

$$0.197 = \frac{9.36 \times 10^{-4} t}{(500 \text{ cm})^2}; \quad t = 5262 \times 10^4 \text{ sec} = \mathbf{609 \text{ days}}$$

$$2.16 \quad \text{a. Eq. (2.53): } C_c = \frac{e_1 - e_2}{\log\left(\frac{\sigma'_2}{\sigma'_1}\right)} = \frac{0.82 - 0.64}{\log\left(\frac{360}{120}\right)} = \mathbf{0.377}$$

$$\text{b. } C_c = \frac{e_1 - e_2}{\log\left(\frac{\sigma'_2}{\sigma'_1}\right)}; \quad 0.377 = \frac{0.82 - e_2}{\log\left(\frac{200}{120}\right)}; \quad e_2 = \mathbf{0.736}$$

2.17 Eq. (2.73): $T_v = \frac{C_v t}{H^2}$. For 60% consolidation, $T_v = 0.286$ (Table 2.11).

Lab time: $t = 8\frac{1}{6} \text{ min} = \frac{49}{6} \text{ min}$

$$0.286 = \frac{C_v \left(\frac{49}{6} \right)}{(1.5)^2}; \quad C_v = 0.0788 \text{ in.}^2/\text{min}$$

Field: $U = 50\%$; $T_v = 0.197$

$$0.197 = \frac{(0.0788)t}{\left(\frac{10 \times 12}{2} \right)^2}; \quad t = 9000 \text{ min} = \mathbf{6.25 \text{ days}}$$

2.18 $U = \frac{30}{60} = 0.5$

$$T_{v(1)} = \frac{C_{v(1)} t}{H_1^2} = \frac{(2)(t)}{\left(\frac{2 \times 1000}{2} \right)^2} = 2 \times 10^{-6} t$$

$$T_{v(2)} = \frac{C_{v(2)} t}{H_2^2} = \frac{(2)(t)}{\left(\frac{1 \times 1000}{2} \right)^2} = 8 \times 10^{-6} t$$

So, $T_{v(1)} = 0.25T_{v(2)}$. The following table can be prepared for trial and error procedure.

$T_{v(1)}$	$T_{v(2)}$	$\frac{U_1}{U_2}$ (Figure 2.22)	$\frac{U_1 H_1 + U_2 H_2}{H_1 + H_2} = U$
0.05	0.2	0.26	0.34
0.10	0.4	0.36	0.473
0.125	0.5	0.40	0.52
0.1125	0.45	0.385	0.50

So, $T_{v(1)} = 0.1125 = 2 \times 10^{-6} t$; $t = 56,250 \text{ min} = \mathbf{39.06 \text{ days}}$

2.19 Eq. (2.84): $T_c = \frac{C_v t_c}{H^2}$. $t_c = 60 \text{ days} = 60 \times 24 \times 60 \times 60 \text{ sec}$; $H = \frac{2}{2} \text{ m} = 1000 \text{ mm}$.

$$T_c = \frac{(8 \times 10^{-3})(60 \times 24 \times 60 \times 60)}{(1000)^2} = 0.0415$$

After 30 days: $T_v = \frac{C_v t}{H^2} = \frac{(8 \times 10^{-3})(30 \times 24 \times 60 \times 60)}{(1000)^2} = 0.0207$

From Figure 2.24 for $T_v = 0.0207$ and $T_c = 0.0415$, $U = 5\%$. So

$$S_c = (0.05)(120) = \mathbf{6 \text{ mm}}$$

After 100 days: $T_v = \frac{C_v t}{H^2} = \frac{(8 \times 10^{-3})(100 \times 24 \times 60 \times 60)}{(1000)^2} = 0.069$

From Figure 2.24 for $T_v = 0.069$ and $T_c = 0.0415$, $U \approx 23\%$. So

$$S_c = (0.23)(120) = \mathbf{27.6 \text{ mm}}$$

2.20 $\phi' = \tan^{-1}\left(\frac{S}{N}\right)$

Normal force, N (lb)	Shear force, S (lb)	$\phi' = \tan^{-1}\left(\frac{S}{N}\right)$ (deg)
50	43.5	41.02
110	95.5	40.96
150	132.0	41.35

From the graph, $\phi' \approx \mathbf{41^\circ}$

2.21 Normally consolidated clay; $c' = 0$.

$$\sigma'_1 = \sigma'_3 \tan^2\left(45 + \frac{\phi'}{2}\right); \quad 30 + 96 = 30 \tan^2\left(45 + \frac{\phi'}{2}\right); \quad \phi' = \mathbf{38^\circ}$$

$$2.22 \quad \sigma'_1 = \sigma'_3 \tan^2\left(45 + \frac{\phi'}{2}\right); \quad 20 + 40 = 20 \tan^2\left(45 + \frac{\phi'}{2}\right); \quad \phi' = 30^\circ$$

$$2.23 \quad c' = 0. \text{ Eq. (2.91): } \sigma'_1 = \sigma'_3 \tan^2\left(45 + \frac{\phi'}{2}\right) = 140 \tan^2\left(45 + \frac{28}{2}\right) = 387.8 \text{ kN/m}^2$$

$$2.24 \quad \text{Eq. (2.91): } \sigma'_1 = \sigma'_3 \left(45 + \frac{\phi'}{2}\right) + 2c' \tan\left(45 + \frac{\phi'}{2}\right)$$

$$368 = 140 \tan^2\left(45 + \frac{\phi'}{2}\right) + 2c' \tan\left(45 + \frac{\phi'}{2}\right) \quad (\text{a})$$

$$701 = 280 \tan^2\left(45 + \frac{\phi'}{2}\right) + 2c' \tan\left(45 + \frac{\phi'}{2}\right) \quad (\text{b})$$

Solving Eqs. (a) and (b), $\phi' = 24^\circ$; $c' = 12 \text{ kN/m}^2$

$$2.25 \quad \phi = \sin^{-1}\left(\frac{\sigma_1 - \sigma_3}{\sigma_1 + \sigma_3}\right) = \sin^{-1}\left(\frac{32 - 13}{32 + 13}\right) = 25^\circ$$

$$\phi' = \sin^{-1}\left(\frac{\sigma'_1 - \sigma'_3}{\sigma'_1 + \sigma'_3}\right)$$

$$\sigma'_3 = 32 - 5.5 = 26.5 \text{ lb/in.}^2; \quad \sigma'_1 = 13 - 5.5 = 7.5 \text{ lb/in.}^2$$

$$\phi' = \sin^{-1}\left(\frac{26.5 - 7.5}{26.5 + 7.5}\right) = 34^\circ$$

Normally consolidated clay; $c = 0$ and $c' = 0$

$$2.26 \quad \sigma_1 = \sigma_3 \tan^2\left(45 + \frac{\phi}{2}\right). \quad \sigma_1 = 150 \tan^2\left(45 + \frac{20}{2}\right) = 305.9 \text{ kN/m}^2$$

$$\frac{\sigma'_1}{\sigma'_3} = \tan^2\left(45 + \frac{\phi'}{2}\right); \quad \frac{305.9 - u}{150 - u} = \tan^2\left(45 + \frac{28}{2}\right); \quad u = \mathbf{61.9 \text{ kN/m}^2}$$

2.27 a. $\phi' = 26^\circ + 10D_r + 0.4C_u + 1.6 \log(D_{50})$

$$= 26^\circ + (10)(0.53) + (0.4)(2.1) + (1.6)[\log(0.13)] = \mathbf{30.7^\circ}$$

b. $\phi' = \frac{1}{ae + b}$

$$a = 2.101 + 0.097\left(\frac{D_{85}}{D_{15}}\right) = 2.101 + 0.097\left(\frac{0.21}{0.09}\right) = 2.327$$

$$b = 0.845 - 0.398a = 0.845 - (0.398)(2.327) = -0.081$$

$$\phi' = \frac{1}{(2.327)(0.68) - 0.081} = \mathbf{33.67^\circ}$$